

# MULTIDRILL ML





Perforazione a rotazione con circolazione diretta o inversa di fluidi, Martello fondo foro, Aste ad elica continua, Geotermia, Carotaggi convenzionali e Wire-line, Micropali, Roto-percussione, Penetrometro dinamico per prove S.P.T.

Rotary drilling with direct or reverse fluids circulation, Down-the-hole hammer, Augers, Geothermie, traditional Coring and wire-line coring, Micropiles, Roto-percussion, Dynamic Penetrometer for S.P.T.

Forage a rotation avec circulation directe ou inverse de fluides, Marteau fond de trou, Tarière continue, Géothermie, Carottages traditionnelles et Carottages Wire-Line, Micro-pieux, Roto-percussion, Penetrometer dynamique S.P.T.

Rotationsbohren mit direktem/indirektem Luft/Schlammspülung, Imlochhammerbohrungen, Schneckebohrungen, Geothermie, Kernbohrungen, Wire-Line, Mikropfähle, Roto-perkussion, S.P.T. Dynamisch Penetrometer

Perforación a rotación con circulación de fluides directa y inversa, Martillo en fondo, Barras helicoidales, Geotermia, Perforaciones Sacatestigos, Wire-Line, Rotopercusion, Sismica.

**MULTIDRILL ML**



La rinnovata serie **MULTIDRILL ML** equipaggiata di un nuovo motore da 100 HP, incrementa ulteriormente le sue prestazioni nei vari impieghi di perforazione. Componenti di elevata qualità, progettazione attenta al minimo dettaglio, costruzione monitorata durante ogni fase di lavorazione, dimensioni invariate rispetto la precedente serie, rendono la nuova **MULTIDRILL ML** ancora più efficiente, compatta e versatile. Per tutto questo, la **MULTIDRILL ML** è uno dei modelli di maggior successo della gamma Fraste, apprezzata da tempo da moltissimi utilizzatori in tutto il Mondo.

The new series of the **MULTIDRILL ML** drilling rig is fitted with a 100 HP diesel engine that gives the opportunity to further enlarge its performances among the various drilling fields it can be used. High quality components, carefully designed and construction stages monitored at any production phase, make the **MULTIDRILL ML** more efficient, compact and versatile, just keeping the dimensions of previous series. With above special features, the **MULTIDRILL ML** is one of the most required models within the Multidrill rigs line and by now many drillers in the World largely appreciate it.



**Pompa schiuma e lubrificatore per martello fondo foro.**  
Foam pump and down-the-hole hammer line lubricator.  
Pompe à mousse et lubrificateur pour marteau fond de trou.  
Schaumpumpe und Öler für Imlochhammer.  
Bomba de espumante y lubricador en línea para martillo en fondo.



**Testa per roto-percussione a 4 velocità.**  
4-speeds rot-percussion rotary head.  
Tête pour roto-percussion à 4 vitesses.  
4-Geschwindigkeiten KDK für Rotoperkussion (Schlaghammer).  
Cabeza de rotacion por rotopercusion de 4 velocidades.



**Testa di rotazione a 2 velocità.**  
2-speeds rotary head.  
Tête de rotation a 2 vitesses.  
2-Geschwindigkeiten KDK.  
Cabeza de rotacion de 2 velocidades.



**Pompa in aspirazione per circolazione inversa.**  
Suction pump for reverse circulation drilling.  
Pompe en aspiration pour circulation inverse.  
Reverse Zirkulation Saugpumpe.  
Bomba en aspiracion para circulacion inversa.



**Compressore rotativo e pompa fango a vite.**  
Vane type air compressor and screw type mud pump.  
Compresseur rotative et pompe a boue a vis.  
Kapselkompressor und Schneckenpumpe.  
Compresor rotativo y bomba para lodos de tornillo.

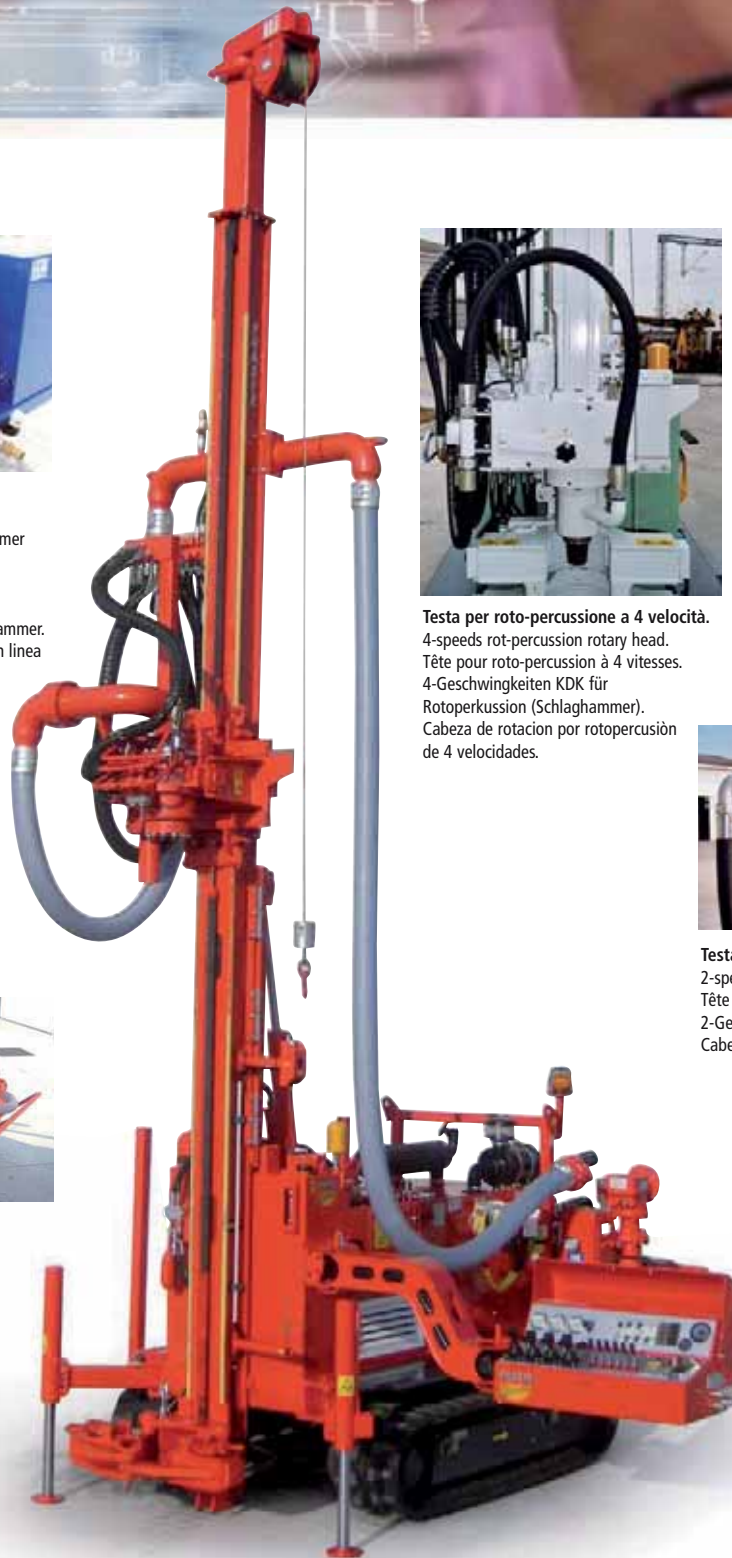

La série rénovée de la foreuse **MULTIDRILL ML**, équipée d'un nouveau moteur de 100 CV, accroît davantage ses performances dans les différentes applications de forage. Ses composants haut de gamme, la conception soignée jusque dans les moindres détails, la construction surveillée dans toutes les phases d'usinage, tout en maintenant les mêmes dimensions que la série précédente, rendent la nouvelle foreuse **MULTIDRILL ML** bien plus performante, compacte et polyvalente. C'est pourquoi la foreuse **MULTIDRILL ML** est l'un des modèles de plus grand succès de la gamme Fraste, appréciée depuis longtemps par de nombreux utilisateurs dans le monde entier.

Die neu gestaltete Reihe **MULTIDRILL ML** in der Ausstattung mit einem neuen 100 PS Motor konnte ihre Leistungen in den diversen Bohrbereichen noch weiter steigern. Bauteile hoher Qualität, sorgfältige Planung bis ins kleinste Detail und die Bauüberwachung während aller Bearbeitungsphasen machen die neue **MULTIDRILL ML** unter Beibehaltung der Abmessungen der vorangehenden Serie noch leistungsfähiger, kompakter und vielseitiger. Aus diesen Gründen ist die **MULTIDRILL ML** eines der erfolgreichsten Modelle im Fraste Sortiment, das seit langem von unzähligen Anwendern in aller Welt geschätzt wird.

La serie renovada **MULTIDRILL ML**, equipada con un nuevo motor de 100 HP, incrementa aún mas sus rendimientos en los distintos trabajos de perforación. Sus componentes de calidad, su planteamiento que tiene en cuenta los mínimos detalles, su construcción controlada en cada fase de trabajo, manteniendo las mismas dimensiones de la serie anterior, vuelve la nueva **MULTIDRILL ML** aun más eficiente, compacta y versátil. Por estas razones, **MULTIDRILL ML** constituye uno de los modelos de mayor éxito de la gama Fraste, que desde hace largo tiempo es sumamente apreciada por los usuarios en todo el mundo.



**Pannello comandi**  
Control panel  
Panneau du commande  
Steuerpult  
Panel de mandos



**Morsa doppia**  
Double clamp  
Double mors  
Doppeltabfangvorrichtung  
Mordaza double



## SPECIAL VERSIONS



Pannello comandi per versione autocarrata.  
Truck version control panel.  
Panneau de commande pour version sur camion  
Lkw-Version Steuerpult.  
Panel de mandos para version sobre camion.



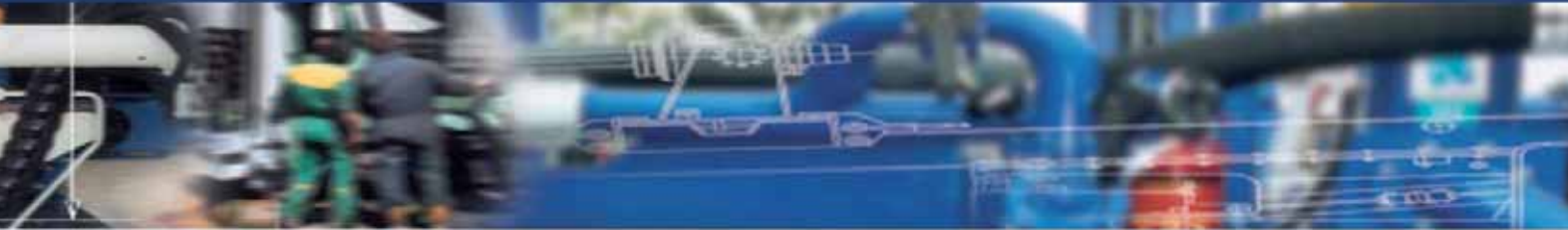

**Penetrometro dinamico SPT.**  
Dynamic Penetrometer for S.P.T.  
Penetrometer dynamique S.P.T.  
S.P.T. Dynamisch Penetrometer  
Penetrometro Dinámico S.P.T.



**Testa di rotazione passante con mandrino.**  
Passing through type rotary head with chuck.  
Tête de rotation passante avec mandrin pour tiges  
Durchgehenden KDK mit Spannkopf.  
Cabeza de rotacion pasante con mordaza para tuberia.



**Morsa semplice e cilindro svita aste.**  
Simple clamp with drill pipes breaking cylinder.  
Simple mors et vérin débloccage de tiges.  
Einfachabfangvorrichtung und hydr. Zylinder für  
Bohrgestänge aufschrauben.  
Mordaza simple y cilindro destornillamiento de barras.

**DATI TECNICI**  
**TECHNICAL DATA**  
**CARACTÉRISTIQUES TECHNIQUES**  
**TECHNISCHE DATEN**  
**DATOS TÉCNICOS**

**PESO**  
**WEIGHT**  
**POIDS**  
**GEWICHT**  
**PESO**

~ 4000 Kg

<b>CARRO</b> <b>CRAWLER UNDERCARRIAGE</b> <b>CHENILLE</b> <b>RAUPENFAHRZEUG</b> <b>CARRO ORUGA</b>	Max larghezza cingoli Max width Largeur max Gesamtbreite Ancho total <b>1450 mm</b>	Passo cingolo Weel base Enpattement Fahrwerk Radstand Paso entre ejes <b>1368 mm</b>	Pressione specifica al suolo Ground pressure Pression au sol Bodendruck Presion especifica al suelo <b>0,6 Kg/cm<sup>2</sup></b>	Velocità di traslazione Travelling speed Vitesse de translation Benegungsgeschwindigkeit Velocidad de traslación <b>2,4 Km/h</b>	Pendenza max. superabile Max gradeability Pente max Steighähigkeit max Pendiente superable <b>60 %</b>
<b>MOTORE DIESEL</b> <b>DIESEL ENGINE</b> <b>MOTEUR DIESEL</b> <b>DIESELMOTOR</b> <b>MOTOR DIESEL</b>	<b>TIER 3</b> <b>V3800 - DI - T - E3B</b> <b>4 Cylinders</b> <b>TURBO</b>	Potenza Power Puissance Leistung Potencia <b>74kW (100 hp)</b> <b>a 2600 RPM</b>	Capacità serbatoio gasolio Fuel tank capacity Capacité réservoir diesel Dieseltankinhalt Deposito de combustible <b>85 l</b>	Consumo Fuel consumption Consommation Kraftstoffverbrauch Consumo <b>240 g/kWh</b>	Capacità serbatoio olio idraulico Oil tank capacity Capacité réservoir d'huile Öltankinhalt Deposito hidráulico <b>110 l</b>
<b>MORSE</b> <b>CLAMP</b> <b>MORSE</b> <b>ABFANGVORRICHTUNG</b> <b>MORDAZA</b>	Morsa doppia Ø Double clamp Ø Double mors Ø Doppelabfangvorrichtung Ø Mordaza double Ø <b>45÷200 mm</b>	Forza di chiusura Clamping force Force de serrage Klemmkraft Fuerza de cierre <b>9700 daN</b>	Coppia svitamento Break-out torque Couple de deserrage Ausdrehungsmoment Fuerza de giro <b>13000 daNm</b>		
<b>ANTENNA</b> <b>MAST</b> <b>MAT</b> <b>LAFETTE</b> <b>ANTENA</b>	Corsa testa di rotazione Rotary head stroke Course tête de rotation Bohrmast Vorschub Carrera cabezal de rotacion <b>3500 mm</b>	Tiro Pull-up Retrait Zugkraft Tiro <b>4000 daN</b>	Spinta Pull-down Poussée Andruck Empuje <b>2000 daN</b>	Velocità di estrazione Extraction speed Vitesse de extraction Ausziehungsgeschwindigkeit Velocidad de extraccion <b>40 m/1'</b>	Velocità di avanzamento Feed speed Vitesse d'avancement Vorschubgeschwindigkeit Velocidad de avance <b>40 m/1'</b>
<b>TESTA ROTANTE</b> <b>ROTARY HEAD</b> <b>TETE DE ROTATION</b> <b>KRAFTDREHKOPF</b> <b>CABEZAL DE ROTACION</b>	Coppia max Max torque Couple maxi Drehmoment max Fuerza de rotacion <b>730 daNm</b>	2/4 velocità / Rotoperkussione 2/4 speeds / Hydraulic drifter 2/4 vitesses / Rotoperkussion 2/4 Drehzahl / Rotoperkussions 2/4 velocidad / Rotoperkusión <b>730 daNm</b>	Velocità max Max speed Vitesse maxi Max Geschwindigkeit Velocidad max <b>840 rpm</b>	2/4 velocità / Rotoperkussione 2/4 speeds / Hydraulic drifter 2/4 vitesses / Rotoperkussion 2/4 Drehzahl / Rotoperkussions 2/4 velocidad / Rotoperkusión <b>840 rpm</b>	
<b>VERRICELLO</b> <b>WINCH</b> <b>TREUIL</b> <b>WINDE</b> <b>CABRESTANTE</b>	Tiro max/ Tamburo fisso Max line pull Fixed drum Force de levage Tambour fixe Max Zugkraft Festtrommelwinde Tiro max Tambor fijo <b>2000 daN</b>	Velocità max Tamburo fisso Max speed Fixed drum Vitesse max Tambour fixe Max. Geschwindigkeit Festtrommelwinde Velocidad max Tambor fijo <b>55 m/1'</b>	Ø fune Tamburo fisso Rope diameter Fixed drum Diamètre du câble Tambour fixe Seildurchmesser Festtrommelwinde Ø cable Tambor fijo <b>10 mm</b>	Capacità fune Tamburo fisso Drum capacity Fixed drum Câble au tambour Tambour fixe Seilkapazität Festtrommelwinde Capacidad de cable Tambor fijo <b>30 m</b>	



## MULTIDRILL ML

ACCESSORI  
ACCESSORIES  
ACCESSOIRES  
ZUBEHÖR  
ACCESORIOS

DATI TECNICI  
TECHNICAL DATA  
CARACTÉRISTIQUES TECHNIQUES  
TECHNISCHE DATEN  
DATOS TÉCNICOS

È disponibile una vasta gamma di accessori per versioni personalizzate a seconda degli impieghi della perforatrice.

Radio comando a distanza per tutte le operazioni di perforazione disponibile a richiesta.

A wide range of drilling accessories is available according to the drilling uses of the rig.

Radio remote control for all drilling functions of the rig is available upon request.

Une vaste gamme d'accessoires personnalisés est disponible selon l'utilisation de la foreuse.

Radio-commande a distance pour toutes les fonctions de foration a la demande.

Es ist eine große Auswahl an Zubehör für personalisierte Versionen verfügbar, je nach dem Einsatz der Bohrmaschine.

Radio-Funkfernsteuerung für alle Bohrarbeiten auf Anfrage verfügbar.

Está disponible una gama amplia de accesorios para versiones personalizadas en relación con los empleos de la perforadora.

Se suministra a petición el radiocomando a distancia para todas las operaciones de perforación.

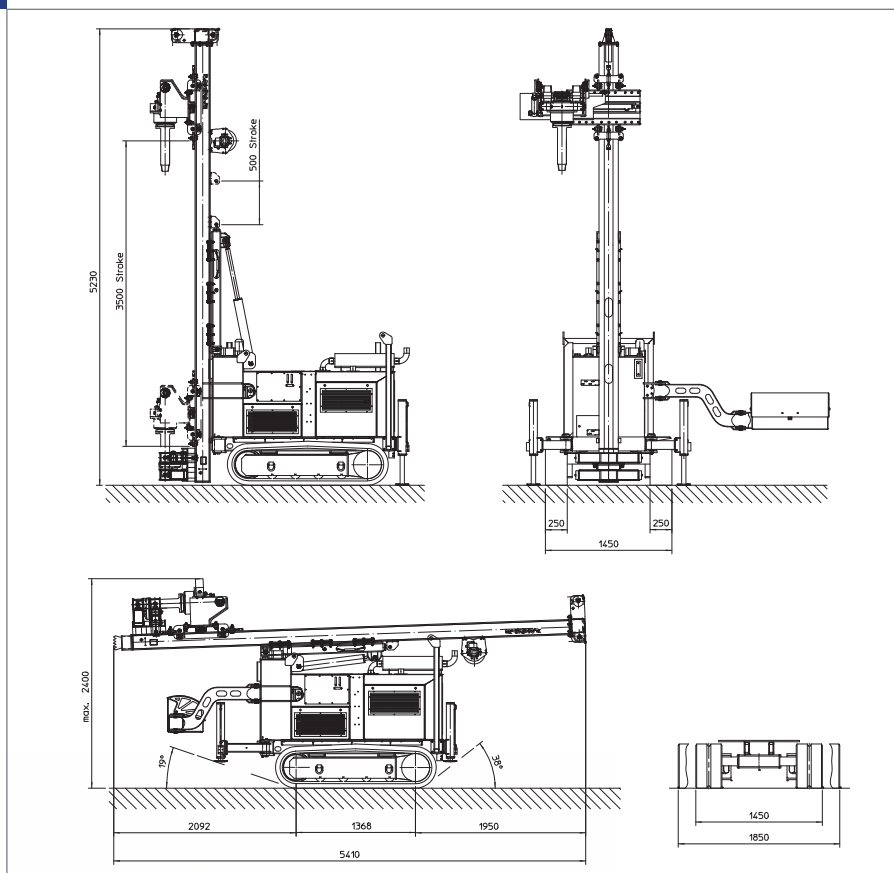

Fraste Spa - 37054 Nogara (VR) Italy - Via Molino di Sopra, 71  
Tel. 0039 0442 510233 - Fax 0039 0442 88426  
e-mail: fraste@fraste.com - www.fraste.com